

# MICEDD

## DEEPWATER DEVELOPMENT

28 - 30 March 2023 | Millennium Gloucester Hotel | London, UK

ORGANIZED BY



Quest Offshore

World Oil®

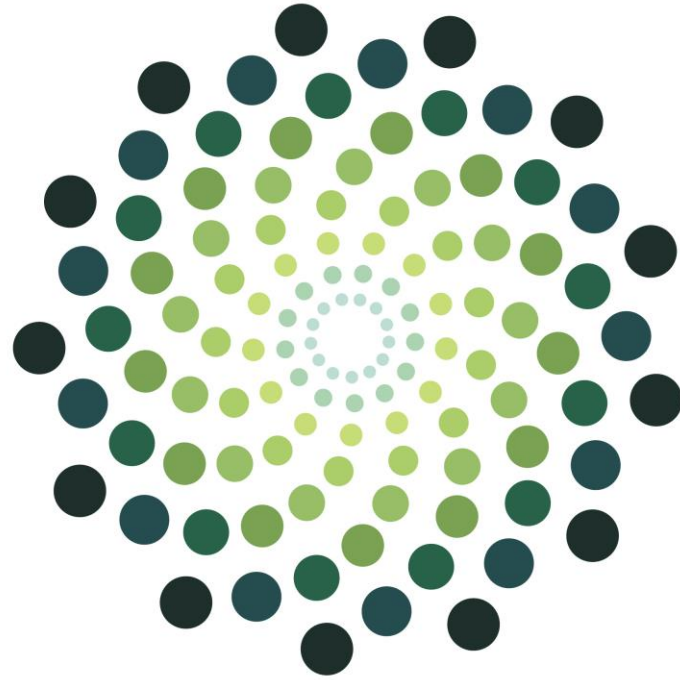

**CSUB**

# GRP – Material Qualification and its use as Modular Support for Pipeline

MCEDD – 30.03.2023

Jon Inge Brattekås, SVP Market & Technology

# Agenda for MCEDD



- CSUB – a composite specialist EPC supplier
- What is a composite and how do we manufacture a composite structure?
- Qualification and testing of Composite Materials
- Some examples of Subsea Solutions
- Modular and Adjustable Pipeline Support solutions

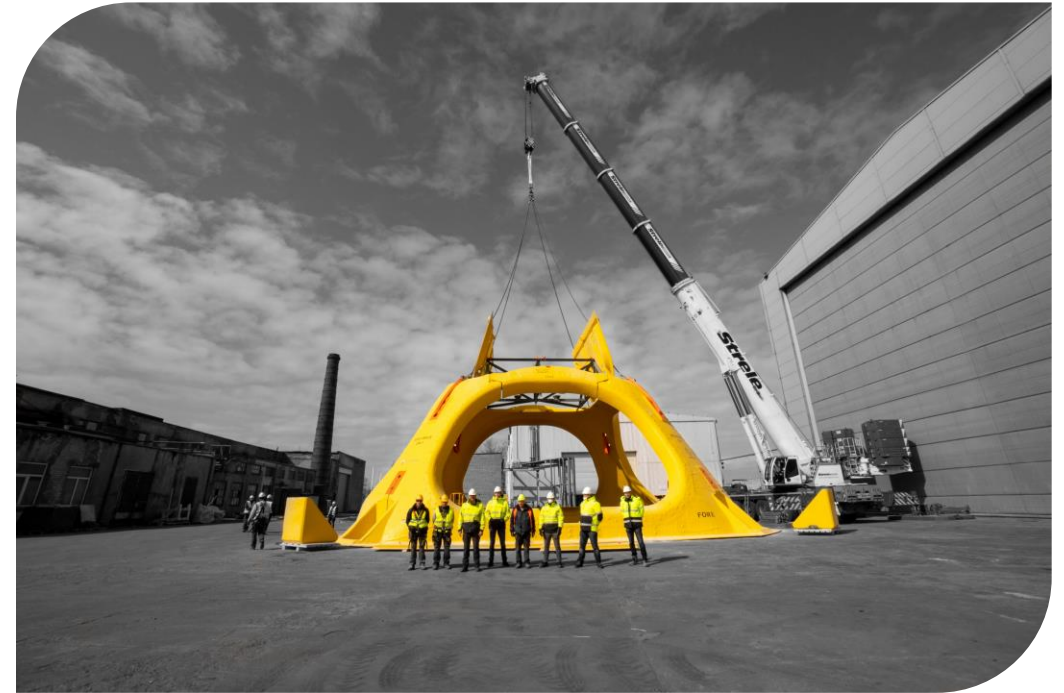

# Who is CSUB



## Company key facts



EPC supplier founded in 1995



250 employees



Certified since 2008

Based in Norway and Lithuania

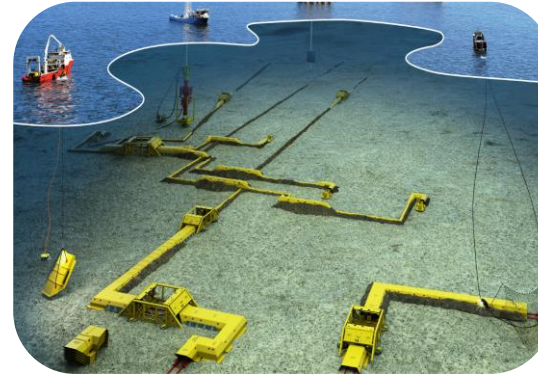

Subsea Protection/Support



Aquaculture Tanks/Process



Renewable – Floating Solar



Civil – Bridges / Floating Swimming Pools

## CSUB mission

*We reduce cost and carbon footprints through better solutions in composite material*

## Our subsea clients



CSUB has delivered more than 10.000 GRP structures/parts to subsea applications since 1995

# Today's use of composite materials



- Transportation
- Sports and recreation
- Pipe & Tank
- Marine
- Infrastructure

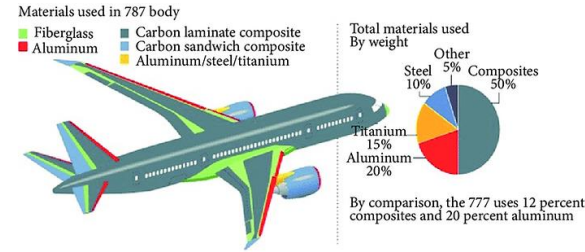
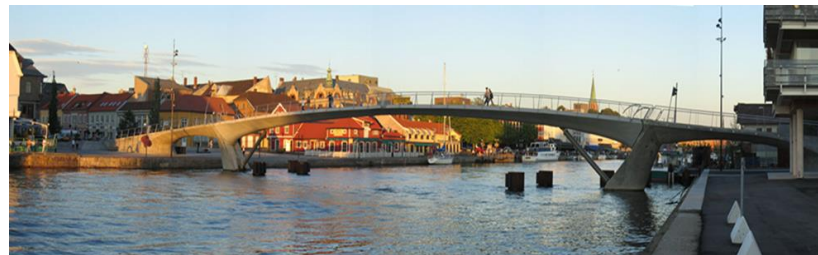

- Aerospace
- Architecture
- Automotive
- Energy Production

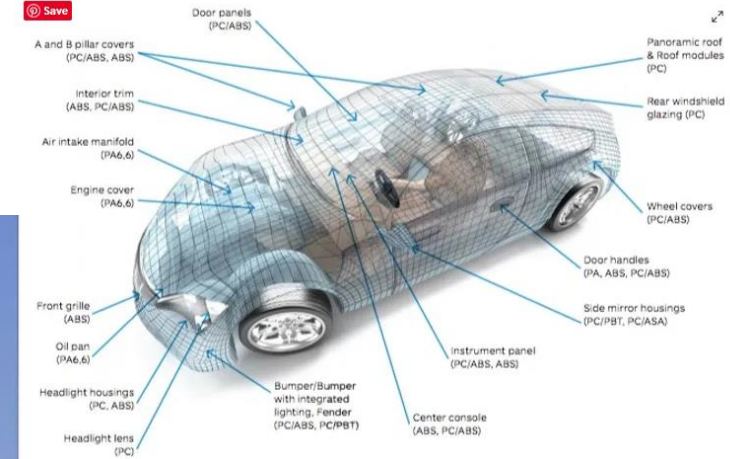

# What is a composite?

## Definition according to Encyclopedia Britannica

**Composite material** a solid material that results when **two or more different substances**, each with its own characteristics, are combined to create a new substance whose properties are superior to those of the original components.



Fiber

+



Polyester

=



CSUB uses primarily **GRP** – Glass fiber Reinforced Polyester (note - Polymer)

Key characteristics:

Strength as steel

Lower E modulus than  
steel

No corrosion

# Composite Material – Benefits – Why use it



## Carbon Footprint

- Reduced Carbon Footprint
- Approx 50% CO<sub>2</sub> footprint compared to steel, mainly due to lower weight.

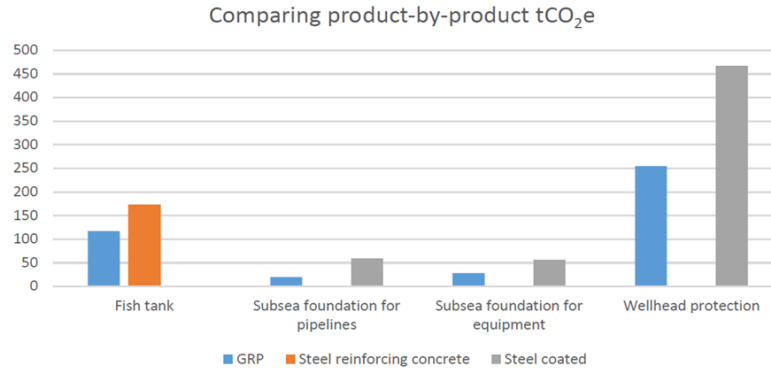

## Stackability

- Reduced campaigns
- Reduce freight cost
- Deployment



## Low Weight

- Normally 1/3 of steel
- Reduced vessel crane requirement
- Less impact on soil

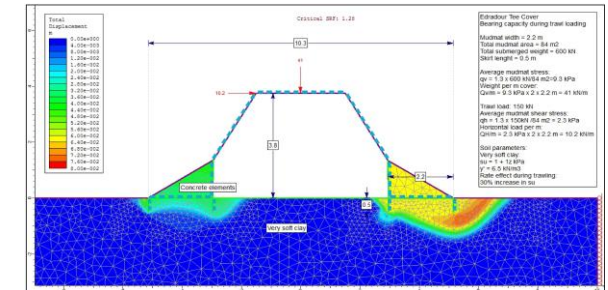

## Other Advantages

- Design Life >50 yrs
- Low life of field cost – no maintenance
- Short delivery time as raw materials are normally on stock
- Cost savings – normally competitive cost compared to steel solutions + cost saving for transport and installation





**DNV-ST-C501 – Composite “bible”**  
Been in use since 2003

**DNV-RP-B302 Effects on Mechanical Properties of Polymers and Composite Materials. New Recommended Practice to determine design life of Composite Materials.**



**Each manufacturer needs to build their database with test results for each combination of fiber and resin from each supplier**

**Standards for loads and load input is given from NORSOK U-001 standards or ISO Standard 13628**

# Composite Material - Testing



Component testing

Type of test	Results	Test standard	Valid test results	Specimen size [mm]*	Laminate lay-up
Tensile E-modulus and strength, longitudinal	EX, XT	ASTM D3039, ISO 527	15	250x25x5	A
Tensile E-modulus and strength, transverse	EY, YT	ASTM D3039, ISO 527	15	250x25x5	A
Compressive strength, longitudinal	XC	ASTM D6641, ISO 14126	15	140x25x7.5	B
Compressive strength, transverse	YC	ASTM D6641, ISO 14126	15	140x25x7.5	B
In-plane shear modulus	GXY, (SXY)	ASTM D3518, ISO 14129	15	250x25x5	C
In-plane shear strength	SXY	ASTM D7078	15	(76x56x5)	C
Interlaminar shear strength	ILSS	ASTM D2344, ISO 14130	15	30x10x5***	A
Fibre fraction, weight ratio	W <sub>f</sub>	ASTM D2584	3	25x25x5	A
Density	P	ASTM D792	3	25x25x5	A
<i>The following tests are only required when specified:</i>					
Impact strength, longitudinal	[kJ/m <sup>2</sup> ]	ISO 179-1	5	80x10x4	A**
Impact strength, transverse	[kJ/m <sup>2</sup> ]	ISO 179-1	5	80x10x4	A**
Water absorption		ISO 62	3		A
Microscopic characterisation of voids		Check and calculate void fraction. Characteristic photo of cross-section.	3	Grind and polish cross-section	B

Testing of composite materials according to recognized standards as shown in table above.

Results of testing used as basis for structural analysis according to DNV-ST-C501 standard

# Composite Material - Testing



Figure 9 Compressive strength - transverse

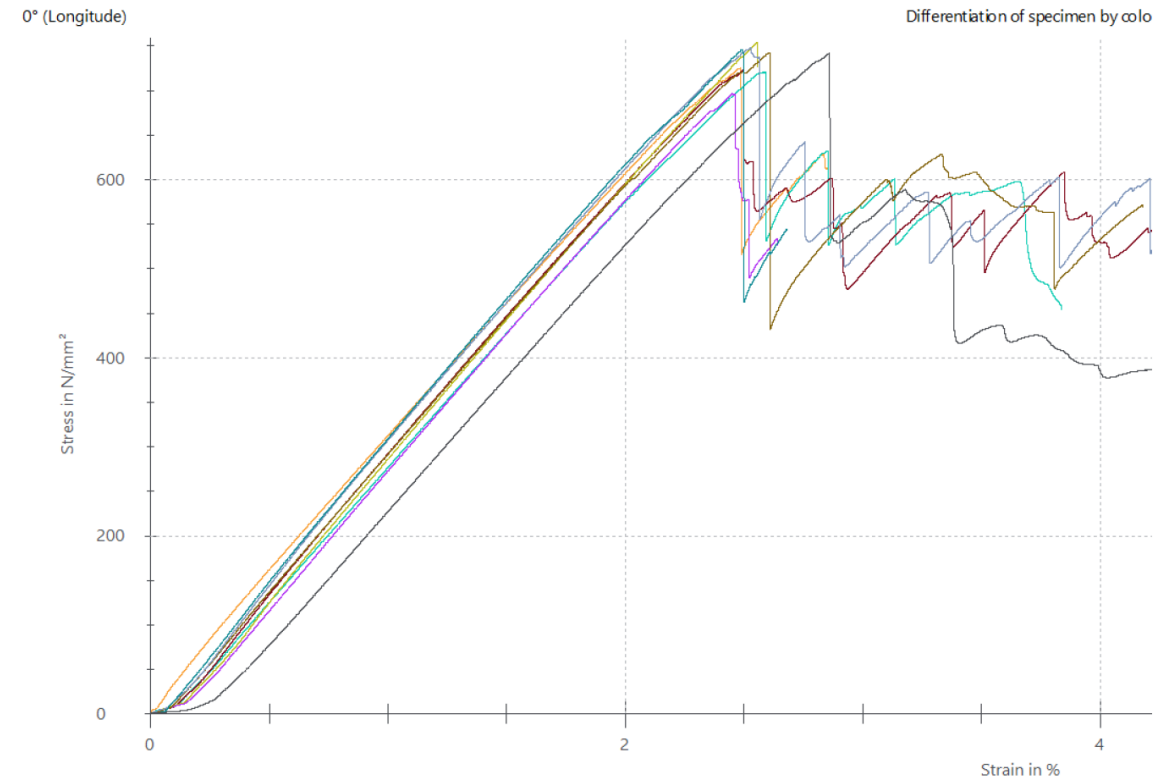

Testing performed according to:  
DNV-RP-B302 Effects on Mechanical Properties of Polymers and Composite Materials.

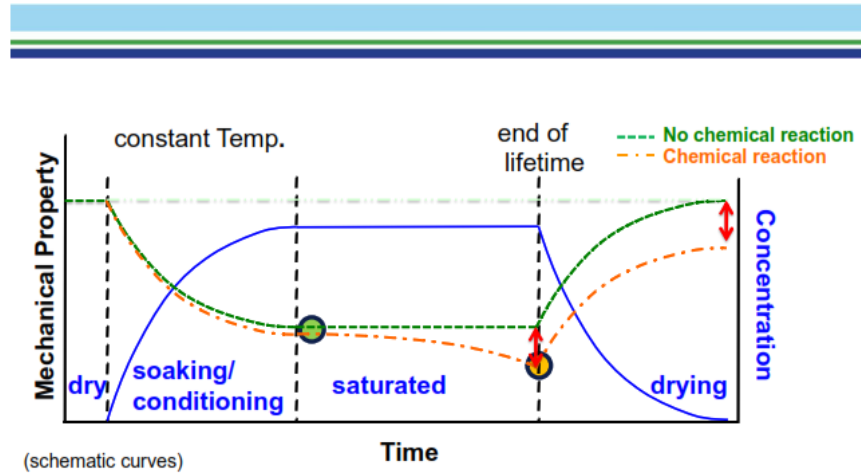

Figure 2-1: Schematic showing the change of a mechanical property with time due to saturating of the material with a fluid and chemical reaction with the material.

Figure showing principle of testing of laminates to determine evt degradation and assess design life.

Main goal of test is to determine:

1. Drop in Mechanical Properties with saturation.
2. Mechanical Properties return to original value after drying.
3. If drop in dried value, chemical degradation is present.

# Composite Material – Long Term Testing - summary



	Dry	Wet	Dried
E-Module	39452	39524	40205
Tension	900	900	900
InterLaminar Shear Strength	42,5	41,58	42,34
In-plane Shear	71,06	66,96	72,57

All values in MPa

All values are equal or higher after saturation and drying. No chemical degradation present



CSUB AS  
Teaterplassen 3  
4836 Arendal  
Norway

DNV AS Energy Systems  
Materials & Structural Integrity  
Advisory – Oslo 4100 NO  
Veritasveien 1  
1363 Høvik  
Norway  
Tel: +47.67.57.99.00  
Legal Entity VAT no.: 945 748 931

Date:  
2022-11-014

Our reference:  
1735230

Your reference:  
Email from CSUB dated of  
2022-02-02

## Example of In-Plane shear test – butterfly test

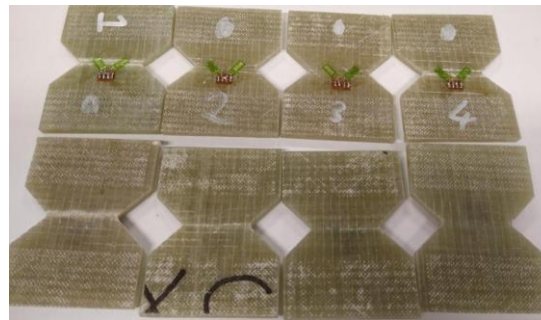
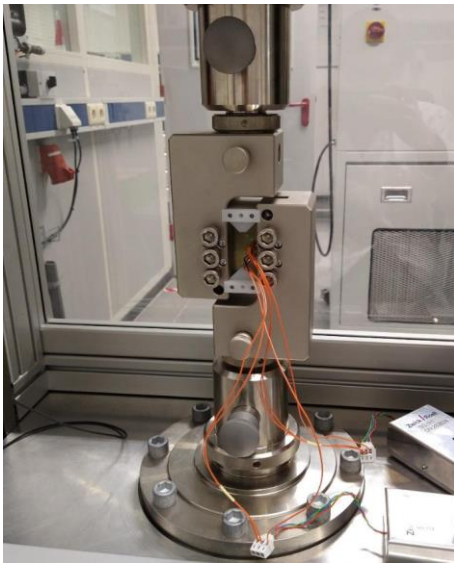

### Letter of Endorsement

CSUB AS has provided glass-fibre-reinforced-plastic (GFRP) composite products and solutions for the oil & gas and renewable industries for about two decades. Over the years, DNV has been involved in several of the CSUB engineering projects, where verifications of the material properties, structural design, production as well as production inspection were essential. Through this work, CSUB products and solutions have demonstrated to be based on durable materials, reliable designs, production quality, in line with best industry practices and compliant with international standards, such as the DNV-ST-C501 on Composite Components.

Regarding GRFP composite materials, DNV's experience and opinion is that GFRP of recognised quality is proven to not be harmful to marine environment, has very low degradation rate in seawater and is proven for use in offshore applications.

# Trawlability

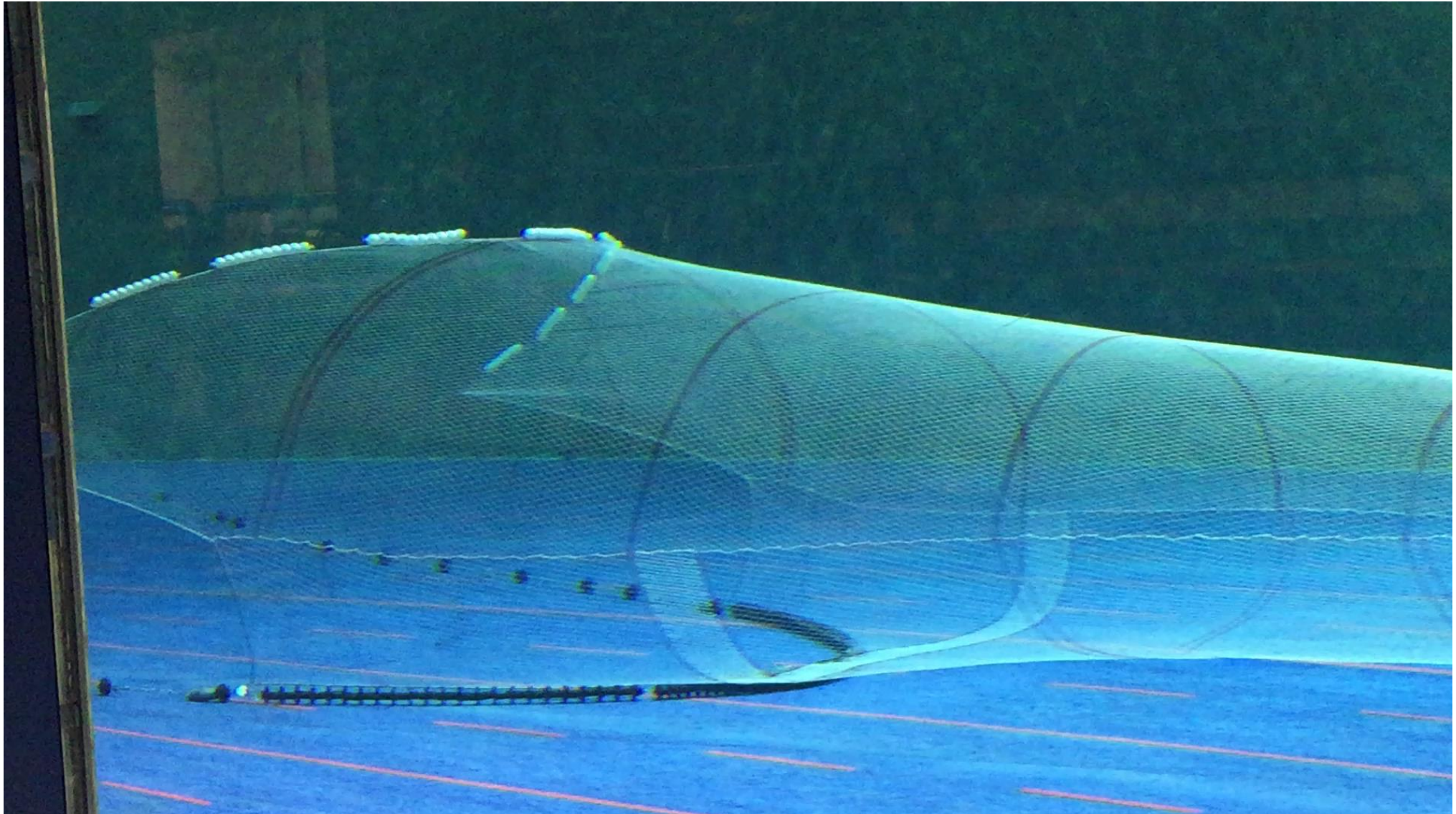

150 kJ Droptest  
at Eydehavn

1080 kg object  
dropped from 14,2 meters

# Vacuum Injection Manufacturing process



Mould construction

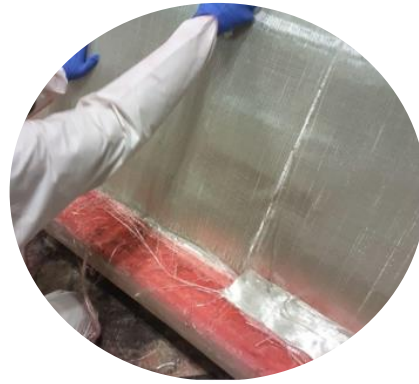
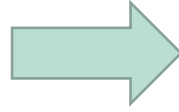

Fiber lay up

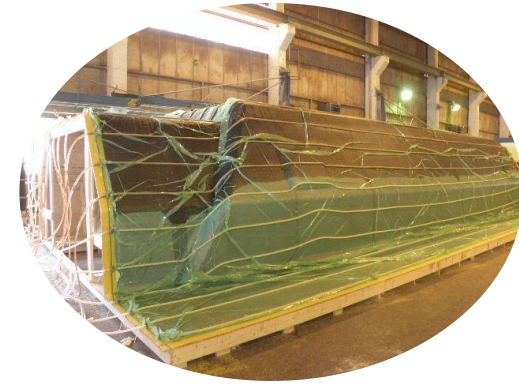
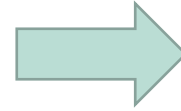

Injection of resin

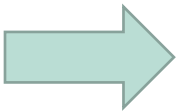

Finishing work (cutting and coating)

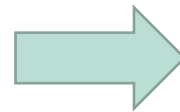

Factory Acceptance test

**Simple covers: 3 days mould construction and 2 days production**  
**Large complex structures: 2-3 weeks mould construction and 2-3 weeks production**



# Large Protection Structures

Wellhead Protection, PLEM/PLET/ILT protection

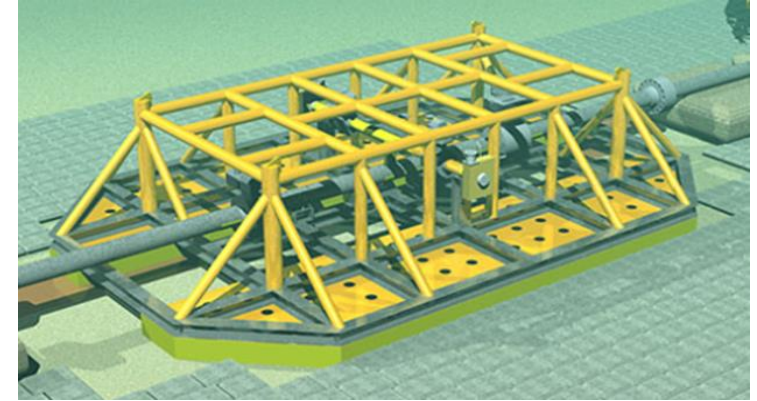

# Protection structures – pipelines and equipment

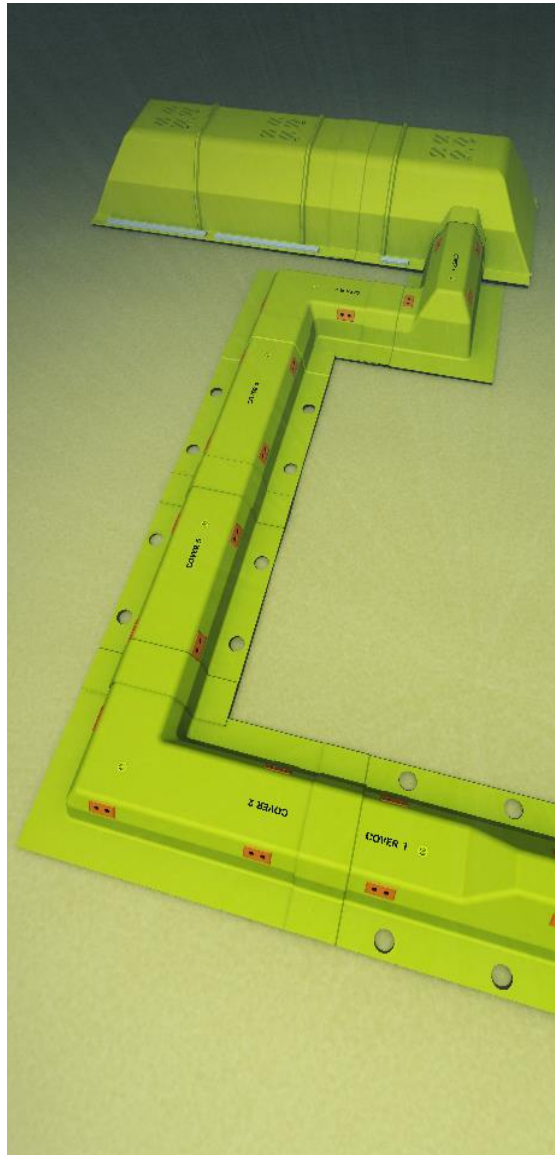

For Freespan protection to touchdown of expansion areas

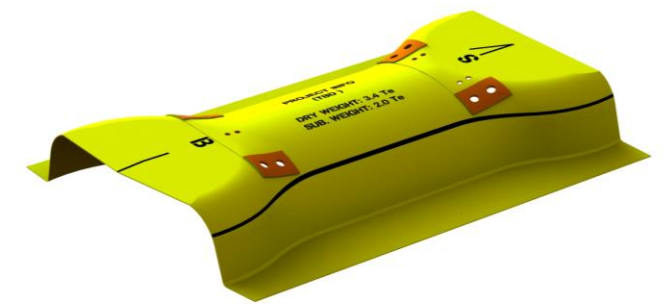
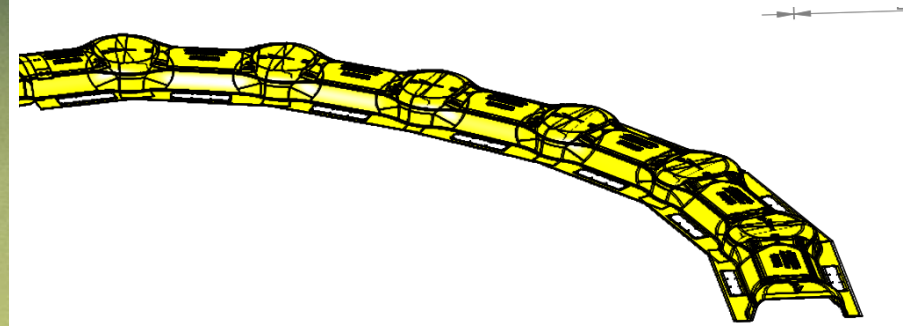

# Protection structures



**Abandoned well structures being installed at Chinguetti field by Oceaninstaller for Petronas winter 2023. Lifetime – 50 yrs++++**

# Subsea Pipeline Solutions



**Cable/Flexible crossings**



**Rigid Pipe Crossing**



**Pipe Support**



**Pipeline Mattresses**

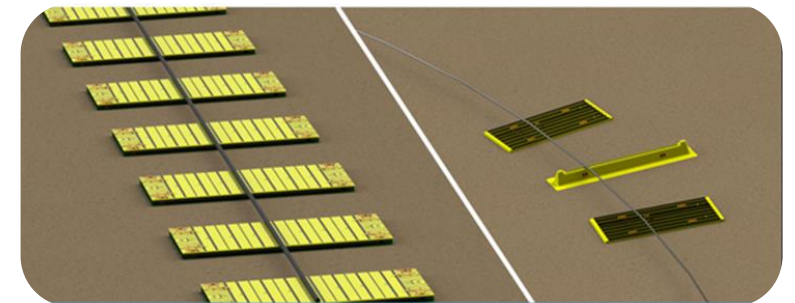

**Buckling Initiator**

# Case – Modular Adjustable Pipeline Support



## The solution

A **modular** concept based on GRP material

Base support with slidable wedges to allow for adjustable height

Insert can be included for additional height adjustments

**Low weight** of support ease the installation and allow for sliding underneath existing pipeline

**Low weight of wedges** allow for **ROV/diver to push** until contact with pipeline is achieved. Then secured with tightening device.

No requirement for corrosion protection

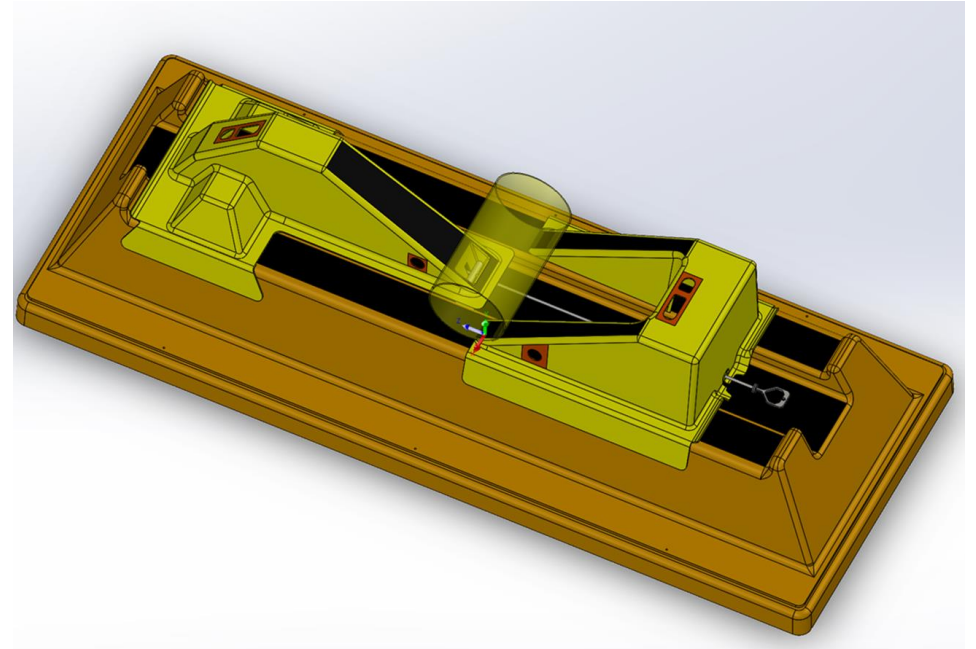

**To be used for crossings and freespan supports**

# Modular Adjustable Pipeline Support

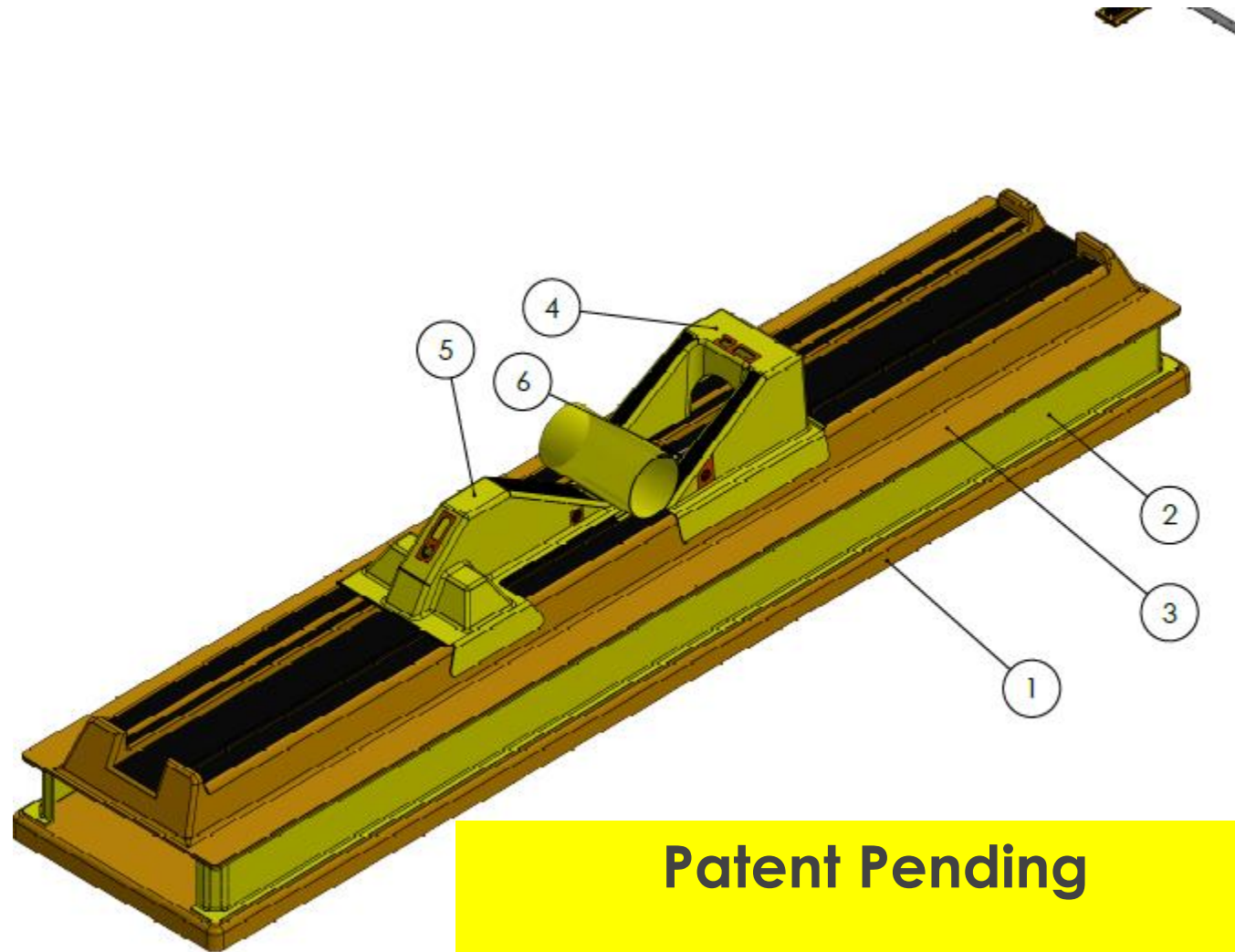

Patent Pending

## Modular solution

- Foundation (1)
- Extension (2)
- Base Structure (3)
- Wedges for height adjustment

This Pipeline support can handle various height as a modular systems - LEGO principle

## Modular Adjustable Pipeline Support as Freespan correction



- Pipeline can have undesirable free span after installation due to seabed unevenness, scouring during operation or other reasons.
- Uncertain exact height between pipeline and soil is a challenge
- Pipeline need to be supported to avoid ViV or max freespan length is exceeded
- Support solution shall be durable over time

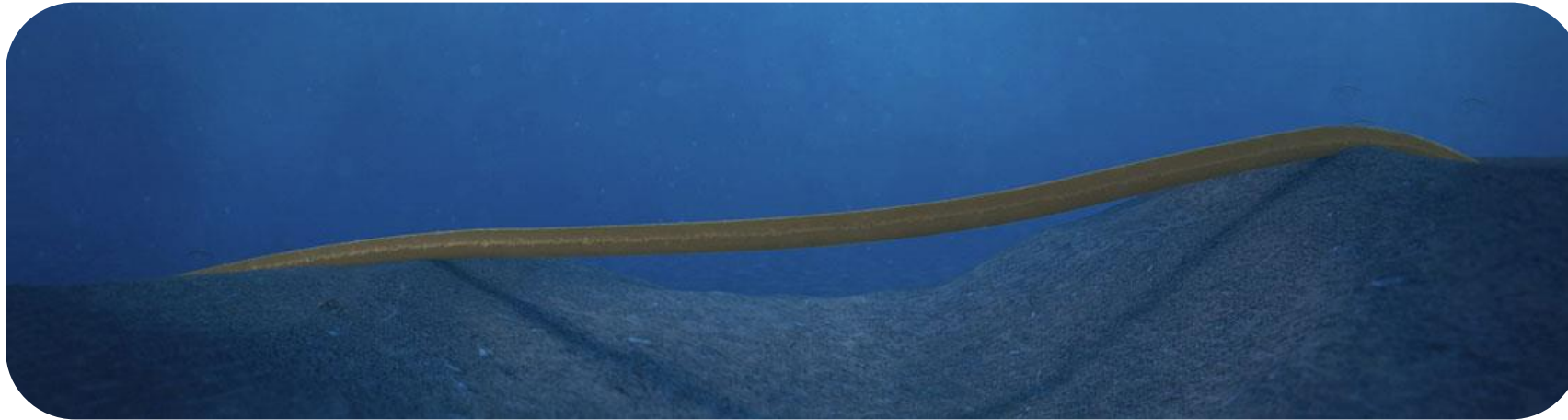
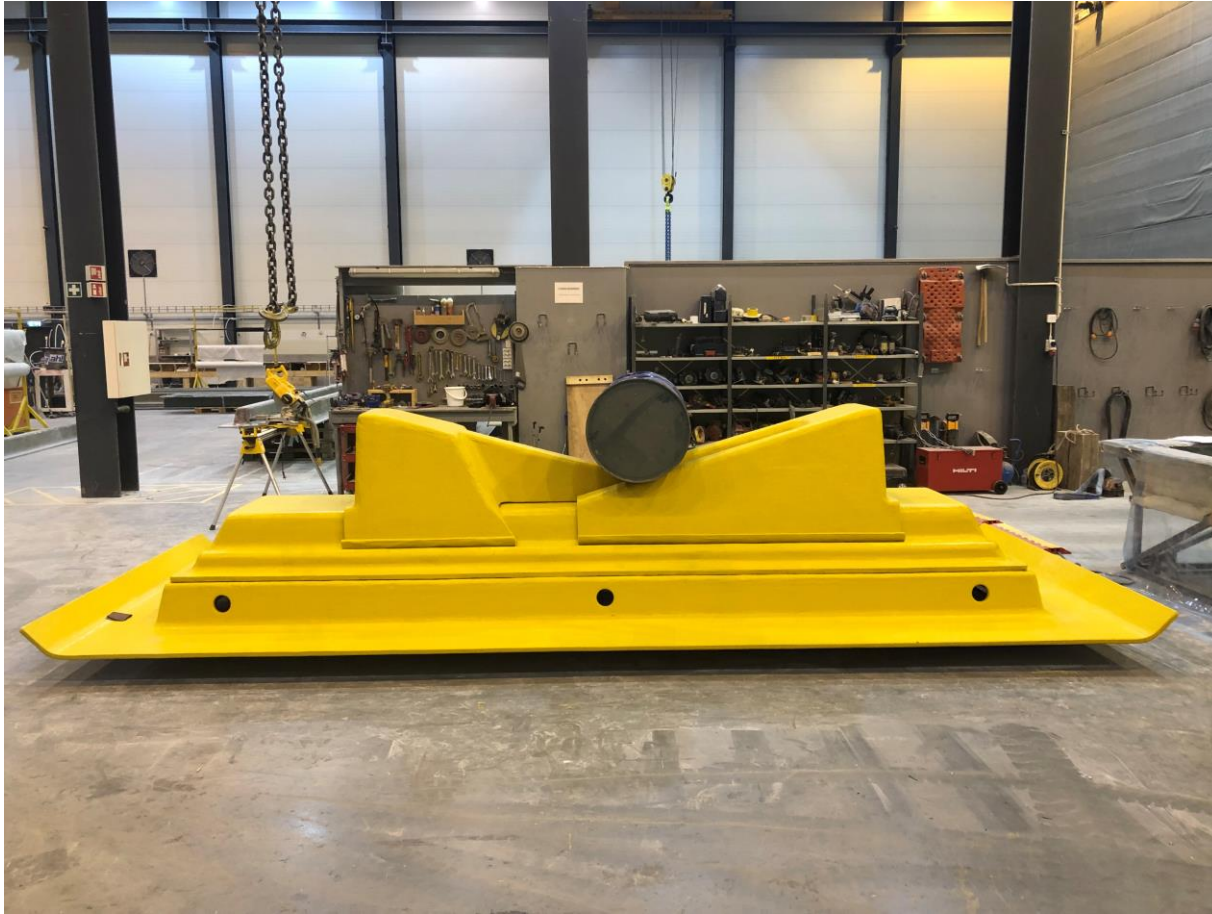
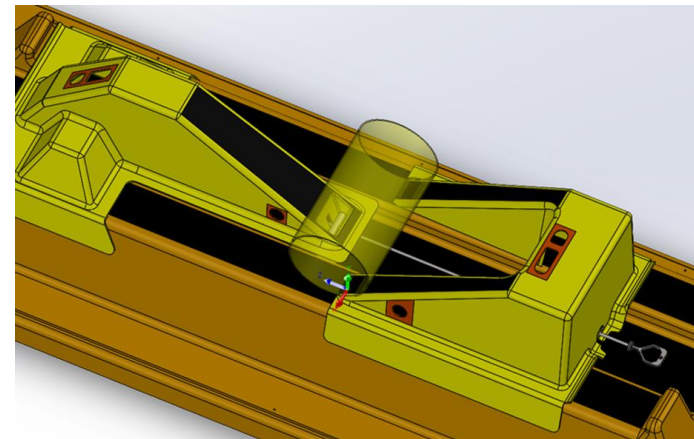

Image courtesy of DNV

# Modular Adjustable Pipeline Support as Freespan correction



- Can be adjusted in height at vessel prior to deployment using Extension part to match freespan height
- Can be installed without lifting the pipeline
- Tightening device operated by ROV or diver





# Case - Freespan correction supports

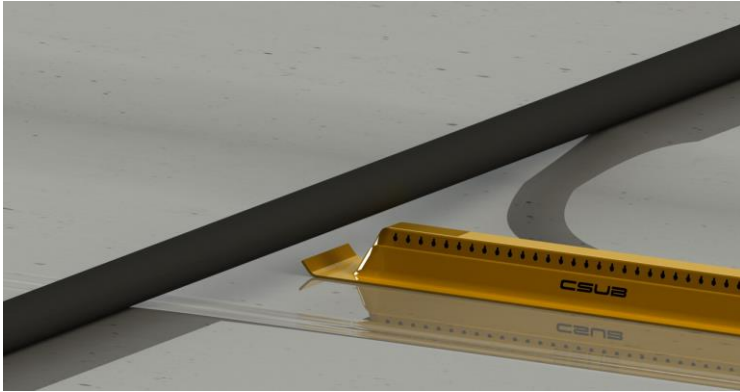

Step 1:  
Prepare for sliding

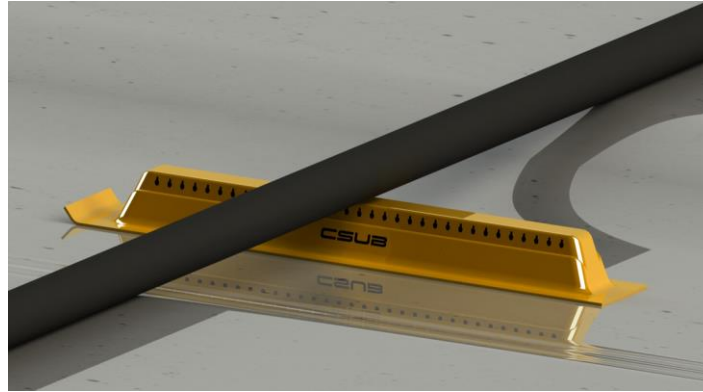

Step 2:  
Slide under main support

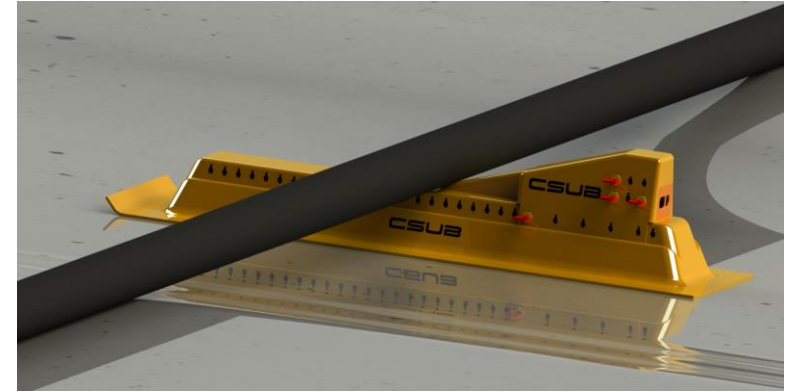

Step 3:  
Install wedge 1

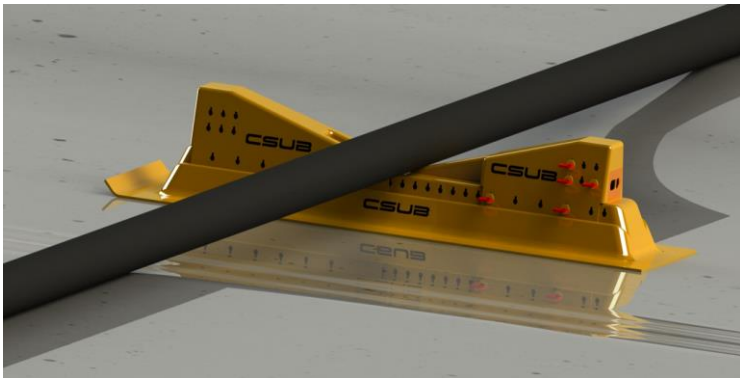

Step 4:  
Install wedge 2

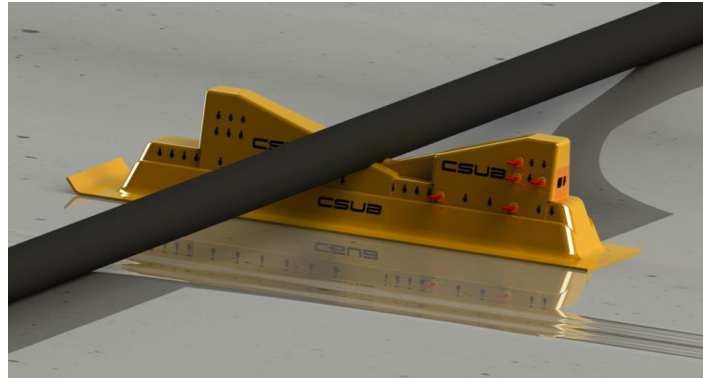

Step 5:  
Lock and tighten wedges

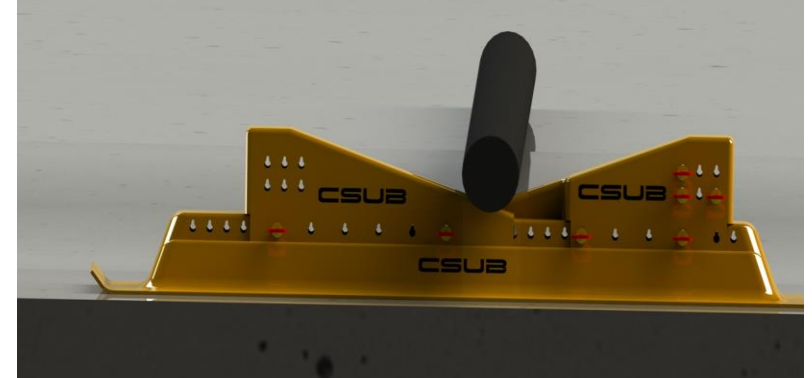

Installation completed

## Modular Adjustable Pipeline Support as Rigid Pipeline Crossing



- Rigid pipeline crossings can be challenging
  - Support heights vary
  - Several designs need to be engineered and fabricated.
- Uneven seabed, contact for all supports might not be obtained.
- Support Height
  - Lowest support – use Foundation and Base structure
  - For higher supports – add add extension
  - Fine adjustment after installation if pipe Insert
- PEHD material on top of wedges/between wedge and base structure ensure low friction and high wear and tear resistance.
- Wedges/pipe can move sideways to allow for lateral movement due to thermal expansion of pipeline

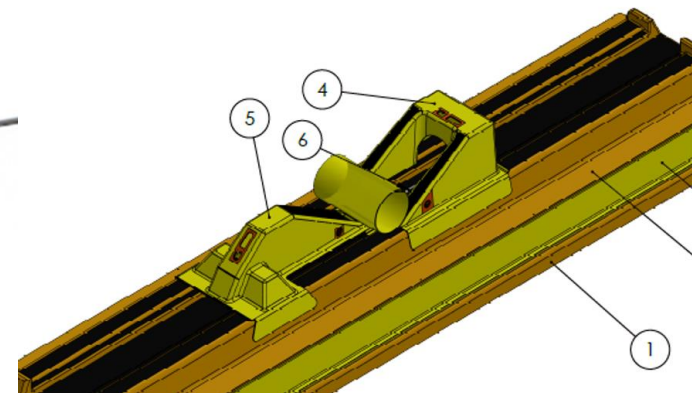

# Status of CSUB Modular Pipeline Support system



- **First prototype fabricated and tested**
- **Improved prototype under fabrication, to be tested in April**
- **Ready for market before summer 2023**

**Thank you for your attention 😊**

**Questions?**

**Jon Inge Brattekås, SVP Market & Technology**  
**+47 90761442 - [jib@csub.com](mailto:jib@csub.com)      [www.csub.com](http://www.csub.com)**

# MICEDD

## DEEPWATER DEVELOPMENT

28 - 30 March 2023 | Millennium Gloucester Hotel | London, UK

ORGANIZED BY



Quest Offshore

World Oil®